



You can rely on Defy. To simplify.



KM520

INSTRUCTION MANUAL
COFFEE MACHINE

Read this manual before operation of the appliance!

Dear Customer,

Congratulations on the purchase of your new Defy appliance!

Please read this manual carefully before using your appliance for the first time and then store it within easy reach for future reference. We trust you will enjoy years of trouble free use.

The user manual:

- This manual will provide you with information on how to safely operate and care for your appliance in order that you gain the maximum benefit from it.
- Pay particular attention to any safety instructions.

Controls and parts

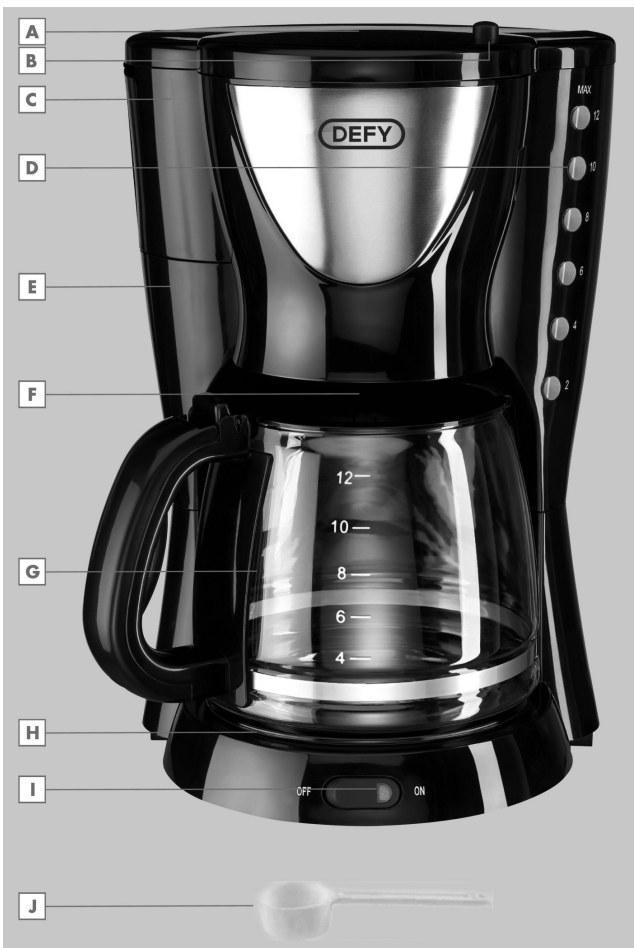

- A** Water tank cover
- B** Release button for swivel filter holder
- C** Swivel filter holder
- D** Water level indicator with MAX marking
- E** Water tank
- F** Drip-stop
- G** Glass jug
- H** Warming plate
- I** On/Off switch (with indicator light)

Accessories

- J** Coffee measuring spoon

1 Safety and set-up

Please read this instruction manual thoroughly prior to using this appliance! Follow all safety instructions in order to avoid damage due to improper use!

Keep the instruction manual for future reference. Should this appliance be given to a third party, then this instruction manual must also be handed over.

- This appliance is intended for private domestic use only and is not suitable for professional-catering purposes. It should not be used for commercial purposes.
- Do not use the appliance in the bathroom.
- Check if the mains voltage on the rating label corresponds to your local mains supply. The only way to disconnect the appliance from the mains is to pull out the plug.
- For additional protection, this appliance should be connected to a residual current protection switch with more than 30 mA. Please contact an electrician for advice.
- Do not immerse the appliance, power cord or power plug in water or any other liquids. Do not hold it under running water and do not clean any parts in the dishwasher. Only the filter basket and glass jug can be cleaned safely in the upper shelf of the dishwasher or with water and washing-up liquid.
- Disconnect the power plug after using the appliance, before cleaning the appliance, before leaving the room, or if a fault occurs. Do not disconnect the plug by pulling on the cord.
- Do not squeeze or bend the power cord and do not rub it on sharp edges in order to prevent any damage.
- Keep the power cord away from hot surfaces and open flame.
- Do not use an extension cord with the appliance.
- Never use the appliance if the power cord or the appliance is damaged.
- Our Household Appliances meet applicable safety standards, if the appliance or power cord is damaged, it must be repaired or replaced by a service centre to avoid any dangers. Faulty or unqualified repair work may be dangerous and cause risk to the user.

- Do not dismantle the appliance under any circumstances. No warranty claims are accepted for damage caused by improper handling.
- Always keep the appliance out of the reach of children.
- **This appliance is not intended for use by persons (including children) with reduced physical, sensory or mental capabilities or lack of experience and knowledge, unless they have been given supervision or instruction concerning the use of the appliance by a person responsible for their safety.**
- **Children should be supervised to ensure that they do not play with the appliance.**
- Before using the appliance for the first time, clean all parts carefully which come into contact with water or coffee. Please see full details in the "Cleaning and Care" section.
- Dry the appliance and all accessories before connecting it to mains supply and before attaching any parts.
- Never operate or place any part of this appliance on or near hot surfaces such as a gas burner, hotplate or heated oven.
- Do not use the appliance for anything other than its intended use. The coffee maker is designed for preparing coffee. Do not use the appliance to heat any other liquids or tinned, jarred, and bottled foods.
- Do not disconnect the plug by pulling on the cord.
- Do not wrap the power cord around the appliance.
- Never use the appliance in or near to combustible or inflammable places and materials.
- Operate the appliance with the delivered parts only.
- Do not use the appliance with damp or wet hands.
- Always use the appliance on a stable, flat, clean, dry, and non-slip surface.

Safety and set-up

- Make sure that there is no danger that the power cord could be accidentally pulled or that someone could trip over it when the appliance is in use.
- The appliance has to be positioned in such a way that the plug is always accessible.
- Avoid contact with hot surfaces and hold the glass jug by the handle only as there is the danger of burning. The glass jug becomes hot during use.
- Do not move the appliance while there is hot liquid in the glass jug or if the appliance is still hot.
- Do not open the cover or swivel filter holder during the brewing process.
- Never fill the appliance above the maximum level indicator. If it is filled above the maximum level, water flows out of the appliance through safety drainage.
- Never operate the appliance if brewing or keeping the coffee hot is not required.
- Fill the appliance with cold and fresh drinking water only.
- Put water in the tank only when the appliance has been unplugged.
- The appliance should not be operated with an external clock timer or separate remote control system.
- Pour water in the water tank carefully.
- In case of any water splashes during water pouring, ensure that glass jug and heating platform are dry.
- Do not place the glass jug on the warm heating platform when the jug is empty.
- Use the glass jug only with the coffee maker.
- Never operate the appliance without water inside.

2 Operation

Preparation

Caution:

First time use: Run the appliance at least 4 times without adding coffee.

Please follow the steps 1 - 2 and 8 - 13 in the "Brewing Coffee" section.

1 Remove all packaging and stickers and dispose of them according to applicable legal regulations.

Operation

2 Before using the appliance for first time, clean all parts which come into contact with water carefully. Please see full details in the "Cleaning and Care" section.

3 Make sure that the appliance is placed in an upright position and on a stable, flat, clean, dry, and non-slip surface.

Brewing Coffee

1 Open the water tank cover **A** and use the glass jug **G** to fill the water tank **E** with the required amount of water, but do not fill past the "max" mark. The brewed amount of coffee will be 10 % less than the filled water, because it is absorbed by the coffee grounds and the filter. The scale on the glass jug is marked in coffee cups, e.g. 4 = 4 cups. For best results it is suggested to operate the appliance with at least a 4 cups coffee serving.

Note

Use only clean, cold, and fresh drinking water.

2 Close the water tank cover **A**.

3 Press the release button **B** for the swivel filter holder.

4 Open the swivel filter holder **C** by swinging it out to the left.

5 Take a suitable paper filter (1 x 4) and insert the paper filter into the swivel filter **C**.

Note

Use only one paper filter at a time. Make sure that the paper filter does not bend or fold.

6 Fill the filter with the desired amount of ground coffee. To do this, you may use the supplied measuring spoon **J**.

7 Close the swivel filter holder **C** until it clicks, which insures that it is closed properly.

8 Place the glass jug **G** on the warming plate **H**.

Caution:

If the swivel filter holder **C** is not closed or the glass jug **G** is not properly seated, the drip - stop function will not function properly. It could cause hot water or hot coffee to overflow.

9 Connect the plug to the wall socket.

10 Turn the appliance on, by setting the On/Off switch **I** to the "ON" position.

Operation

– The On/Off switch **I** illuminates and the brewing process begins.

Notes

The brewing process can be stopped at any time by setting the On/Off switch **I** to the “OFF” position.

The appliance is equipped with a drip-stop **F** located underneath the swivel filter holder **C** and enables you to briefly remove the glass jug **G** to pour coffee before the water has finished running through the machine.

Caution

Ensure that you place glass jug **G** on the warming plate **H** quickly (max. 30 second delay). Otherwise the brewed coffee from the filter could overflow. If you want to use the glass jug for more than 30 seconds, switch off the appliance.

Never open the swivel filter holder **C** during the brewing process, even if no water is draining from the filter. Extremely hot water or coffee can spill out from the swivel filter holder and cause injury. If water or coffee is not draining from the swivel filter holder, immediately unplug the appliance and wait 10 minutes before opening and checking the swivel filter holder.

When the brewing process ends and the water level indicator with MAX marking **D** is empty, there will still be hot liquid in the swivel filter holder **C**. Wait a few minutes for the rest of the liquid to drip into glass jug **G**.

11 Remove the glass jug **G** from the warming plate **H**, as soon as the brewing process has finished and the glass jug **G** is filled. The coffee is ready for use.

12 To turn the appliance off, set the On/Off switch **I** to the “OFF” position.

– On/Off switch **I** turns appliance on and off.

13 Disconnect the appliance from the wall socket.

Note

If you want to continue the brewing process, repeat the procedure from 1 to 13. Let the appliance cool down at least 15 minutes between each brewing process.

Hints and Tips

Use softened or filtered water to prevent lime build-up. Store unused coffee in a cool, dry place. After opening a package of coffee, reseal it tightly to maintain its freshness.

Do not reuse the coffee sediment in the filter since this will reduce the flavour.

Reheating coffee is not recommended as coffee is at its peak flavour immediately after brewing.

3 Information

Cleaning and care

Caution

Never use petrol, solvents, or abrasive cleaners, or metal objects and hard brushes to clean the appliance.

Never put the appliance or power cord in water or any other liquid.

1 Turn the appliance off and disconnect it from the wall socket.

2 Allow the appliance to cool down.

3 Remove the glass jug **G**.

4 Press the release button **B** for swivel filter holder and swing out the swivel filter holder **C** to far left position. Remove the paper filter and dispose it with the coffee sediment.

5 To remove the swivel filter holder **C**; grasp it from the bottom and lift it slightly up. After the bottom hinge is released from its place, tilt the swivel filter holder slightly so that the bottom hinge moves outwards from the appliance. Then, hold down the swivel filter holder, so that the upper hinge releases from its place and the swivel filter holder detaches from the appliance (see the figure below).

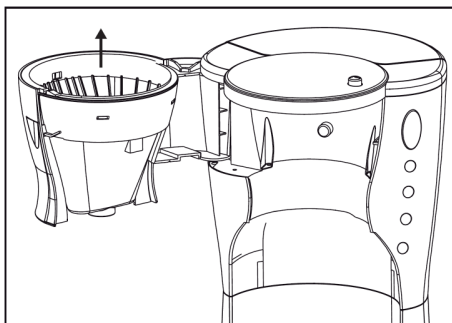

6 Clean the swivel filter holder **C** by placing under running water and using a small amount of mild cleanser. The swivel filter holder **C** and glass jug **G** can be cleaned in the upper shelf of the dishwasher or under running water.

Information

7 Use a damp soft cloth and some mild cleanser to clean the exterior of the appliance.

8 To insert the swivel filter holder **C** after cleaning, follow the instructions at step **5** in the reverse order. Make sure that the upper hinge is placed into its seat properly.

9 Place glass jug **G** onto warming plate **H**.

Note

Before using the appliance after cleaning, dry all parts carefully with a soft cloth or paper towel.

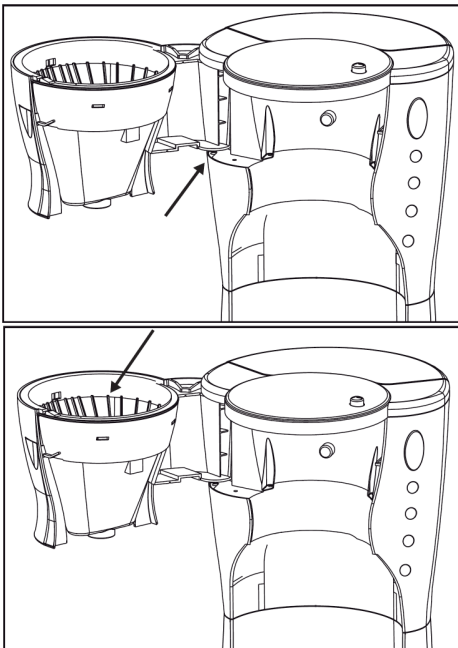

Descaling the appliance

Descaling extends the life of your appliance. Descale your coffee machine at least 4 times per year. The period depends on the water hardness in your area. The harder the water is, the more often the appliance has to be descaled.

1 Purchase a suitable descaler from a speciality store. Please ask naming the device.

2 Prior to commencing the descaling process, thoroughly read the manufacturer's package insert for the descaler.

Should the manufacturer's instructions differ from the ones listed below, then follow the manufacturer's instructions.

Note

You can also use white vinegar and lemon juice instead of a commercially available descaler.

3 Fill the water tank to the MAX marking and add descaler.

Mixing ratio: 4 parts water to 1 part descaler.

4 Turn the appliance ON and allow approximately one large coffee cup to run through the appliance.

5 Turn the appliance off.

6 Let the mixture soak for about 15 minutes.

7 Repeat steps 4 – 6.

8 Now turn the appliance on and let the entire mixture run through.

9 Fill the water tank with cold, fresh drinking water and run all the water through.

10 Repeat step 9 four times.

11 Now you may brew coffee again.

Storage

If you do not plan to use the appliance for a long period of time, please store it carefully. Make sure the appliance is unplugged and completely dry. Store the appliance in a cool, dry place. Make sure the appliance is kept out of the reach of children.

Environmental note

This appliance has been made from high quality materials and parts which can be reused and are suitable for recycling. Do not dispose of the appliance with normal household waste at the end of its service life. Consult your local authorities for disposal information and facilities available.

Help protect the environment by recycling used appliances.

Technical data



This product conforms to the European directives 2004/108/EC, 2006/95/EC and 2009/125/EC.

Power supply: 230 V~, 50/60 Hz

Power: 950 W

Max. water volume: 1.8 L

Technical and design modifications reserved.

Service Centres

If you have followed the instructions and still have a problem, contact the nearest Defy Service Centre. They will be able to advise you on any aspect of the appliance.

South African Service Agents:

BLOEMFONTEIN

160 Long Street, Hilton, Bloemfontein 9301
Tel: 051 400 3900
Bloemfontein.Service@defy.co.za

CAPE TOWN

5A Marconi Rd. Montague Gardens, 7441
Tel: 021 526 3000
CapeTown.Service@defy.co.za

DURBAN

35 Intersite Avenue, Umgeni Business Park,
Durban, 4051
Tel: 031 268 3300
Durban.Service@defy.co.za

EAST LONDON

16 Bowls Rd. Arcadia, East London, 5201
Tel: 043 743 7100
EastLondon.Service@defy.co.za

JOHANNESBURG

Cnr. Mimetes & Kruger Sts. Denver ext.12
Johannesburg, 2094
Tel: 011 621 0200 or 011 621 0300
Gauteng.Service@defy.co.za

POLOKWANE

87 Nelson Mandela Drive, Superbia 0699
Tel: 0152 92 1166 / 7 / 8 / 9
Polokwane.Service@defy.co.za

PORT ELIZABETH

112 Patterson Road, North End, Port Elizabeth
6001
Tel: 041 401 6400
PortElizabeth.Service@defy.co.za

PRETORIA

Block A1 Old Mutual Industrial Park,
Cnr. D.F.Malan Drive & Moot Str. Hermanstad,
0082
Tel: 012 377 8300
Pretoria.Service@defy.co.za

Sub-Saharan Africa Service Agents:

ZAMBIA: SOUTHGATE INVESTMENTS LTD

Plot 1606, Sheki Sheki Road
P.O. Box 33681
Lusaka, 10101, Zambia
Tel: +260 0211 242332/3
Fax: +260 0211 242933
sgiservicecentre@microlink.zm

NAMIBIA: ATLANTIC DISTRIBUTORS (PTY) LTD

10 Tienie Louw Street, Northern Industrial Area
P.O. Box 21158, Windhoek, Namibia
Tel: (061) 216162
Fax: (061) 216134
atlantic@mweb.com.na

ZIMBABWE: TRADECOMAFRICA

Trade Com Africa, 183 Loreley Crescent
Msasa, Harare, Zimbabwe
Tel: +263 4 486165/6
Cell: +263 772 469010
Cell: +263 772 469011

BOTSWANA: RAY MORGAN AGENCIES

RMA Service Centre, Plot 48, East Gate
Gaborone International Commerce Park
Kgale View, Gaborone
Botswana
Tel: +267 390 3996 / 390 3912
Fax: +267 318 7376
Cell: +267 7134 6539
service@rma.co.bw; raja@rma.co.bw

SWAZILAND: LYNDS DISTRIBUTORS

P.O Box 716, Mbabane, Swaziland, H100
Tel: (00268) 2515 4310/8
Fax: (00268) 2518 4318

MOZAMBIQUE: COOL WORLD. LDA

Rua da Resistencia No. 97B R/C
Cell: +258 84 44 61 234
coolworldlda@hotmail.com
Nosso Show Room
Av: da Industrias, Parcela No.735 * 735A
Machava, Maputo

**OTHER AREAS ARE SERVICED BY OVER 200 AUTHORISED SERVICE AGENTS.
PLEASE CONSULT THE NEAREST REGIONAL DEFY SERVICE CENTRE FOR DETAILS.**

5 Warranty

This certificate is issued by DEFY APPLIANCES (PTY) LIMITED manufacturers of Defy and Ocean products, hereinafter the Company, to the original purchaser only, of the appliance described on the certificate and shall constitute the only warranty given in respect of this appliance.

The Company warrants to the original purchaser that for a period of ONE YEAR from date of purchase the appliance is free from defect under normal domestic use, both in workmanship and material, subject to the following conditions.

1. Repair or replacement of any part of this appliance, found by the Company to be defective, shall be at the election of the Company. The Company reserves the right to effect such service through any of its Service Divisions or Authorised Service Dealers. The cost of such service shall be borne by the Company in full, provided that the appliance is located no further than 50km from a Company Service Centre or an Authorised Service Dealer. Where the appliance is located beyond the 50km radius, the purchaser shall be liable for the standard travelling charges, as determined by the Company.
2. Vitreous enamelware, fuses and lamps are specifically excluded from these warranties. It is an express condition of these warranties that the purchaser takes due care and attention in the use and maintenance of the appliance. Abuse, misuse in conflict with operating instructions, connection to incorrect voltages and subjection to commercial use shall release the Company from its obligations.
3. This warranty shall become void and cease to operate if the appliance is dismantled by, or any repairs to the appliance are effected by any persons not duly authorised by the Company, or if substitute parts not approved by the Company are used in the appliance, or if the serial number of the appliance is removed.
4. The Company shall not be responsible for damages resulting from fire, flood, civil disturbances or any Act of God. The Company shall not, in terms of these warranties be responsible nor held liable for any consequential loss or damage of any kind caused by or due to the failure or malfunction of the appliance.
5. The Company shall not be responsible for transportation or other costs other than those incurred within the provisions of Point 1 of this Certificate.
6. **For warranties in the Republic of South Africa and Sub-Saharan Africa, please contact your nearest Defy office. Please refer to page 7 for respective South African service agents and Sub-Saharan Africa service agents.**
7. Where service is requested under warranty and no fault or defect can be found by the Company, all costs incurred will be for the purchaser's account.
8. This Certificate as well as your invoice will serve as proof of purchase. For the purpose of warranty, it will be essential to produce this Certificate and invoice. Failure to do so, will render the purchaser liable for service costs.

**KEEP THIS CERTIFICATE AND SALES INVOICE AS PROOF OF
PURCHASE FOR WARRANTY PURPOSES.**